

OPERATION AND INSTALLATION

Decentralised ventilation unit with heat recovery

- » VLR 70 L Trend EN
- » VLR 70 S Trend EN

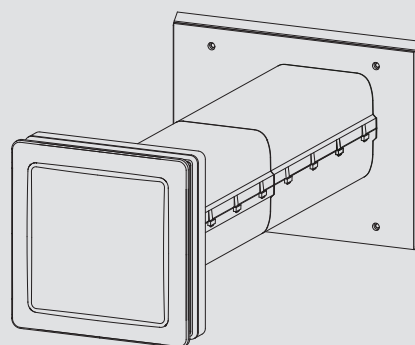

STIEBEL ELTRON

SPECIAL INFORMATION

OPERATION

1. General information	3
1.1 Safety instructions	3
1.2 Other symbols in this documentation	3
1.3 Units of measurement	3
1.4 Standardised output data	3
2. Safety	4
2.1 Intended use	4
2.2 Incorrect use	4
2.3 General safety instructions	4
2.4 Test symbols	4
3. Appliance description	4
4. Settings	5
4.1 Controls	5
4.2 Differential mode	5
4.3 Cross-ventilation	5
4.4 Fan stage	5
4.5 Intensive ventilation	5
4.6 Ventilation pause	6
4.7 Filter change interval	6
4.8 Brightness of the LED indicators	6
4.9 Reading the number of hours run	6
5. Cleaning, care and maintenance	6
5.1 Cleaning	6
5.2 Replacing filters	6
5.3 Cleaning heat exchangers	8
5.4 Assembling the appliance	9
6. Troubleshooting	10
7. Appliance shutdown	10
8. Recommissioning	10

INSTALLATION

9. Safety	11
9.1 General safety instructions	11
9.2 Instructions, standards and regulations	11
9.3 Operation of the appliance in buildings with combustion equipment	11
10. Appliance description	12
10.1 Standard delivery	12
10.2 Accessories	12
11. Preparation	12
11.1 Transport	12
11.2 Installation site	12
11.3 Wall outlet	13
11.4 Control unit and programming unit	14
11.5 Power supply unit	14
12. Installation	15
12.1 Wall mount casing	15
12.2 Securing the external cover base plate	16
12.3 Foaming	16
12.4 Sealing off	17
12.5 Insulating the wall mount casing	17
12.6 Sealing the external cover base plate	17

12.7 Electrical connection	18
12.8 Installing the programming unit	20
12.9 Installing the fan unit	21
12.10 Installing the internal panel	21
13. Commissioning	22
13.1 Initial start-up	22
13.2 Recommissioning	22
14. Settings	23
14.1 Scanning software/hardware statuses	23
15. Appliance shutdown	23
15.1 Temporary shutdown	23
15.2 Shutdown for a prolonged period	23
16. Specification	23

GUARANTEE | ENVIRONMENT AND RECYCLING

FILTER CHANGE REPORT

SPECIAL INFORMATION

- The appliance may be used by children aged 8 and older and persons with reduced physical, sensory or mental capabilities or a lack of experience and know-how, provided that they are supervised or they have been instructed on how to use the appliance safely and have understood the potential risks. Children must never play with the appliance. Children must never clean the appliance or perform user maintenance unless they are supervised.
- Observe all applicable national and regional regulations and instructions during installation.
- Observe minimum clearances (see chapter "Preparations / Installation site").
- The connection to the power supply must be in the form of a permanent connection. Ensure the appliance can be separated from the power supply by an isolator that disconnects all poles with at least 3 mm contact separation.
- Observe the fuse protection required for the appliance (see chapter "Specification / Data table").

OPERATION

1. General information

The chapters "Special information" and "Operation" are intended for both users and qualified contractors.

The chapter "Installation" is intended for qualified contractors.



Note

Read these instructions carefully before using the appliance and retain them for future reference.
Pass on the instructions to a new user if required.

1.1 Safety instructions

1.1.1 Structure of safety instructions



KEYWORD Type of risk
Here, possible consequences are listed that may result from failure to observe the safety instructions.
► Steps to prevent the risk are listed.

1.1.2 Symbols, type of risk

Symbol	Type of risk
	Injury
	Electrocution
	Burns (burns, scalding)

1.1.3 Keywords

KEYWORD	Meaning
DANGER	Failure to observe this information will result in serious injury or death.
WARNING	Failure to observe this information may result in serious injury or death.
CAUTION	Failure to observe this information may result in non-serious or minor injury.

1.2 Other symbols in this documentation



Note

General information is identified by the adjacent symbol.
► Read these texts carefully.

Symbol	Meaning
	Material losses (appliance damage, consequential losses and environmental pollution)
	Appliance disposal

► This symbol indicates that you have to do something. The action you need to take is described step by step.

Symbol	Meaning
	LED off
	LED flashes
	LED illuminates

1.3 Units of measurement



Note

All measurements are given in mm unless stated otherwise.

1.4 Standardised output data

Information on determining and interpreting the specified standardised output data

Standard: EN 13141-8

The output data specifically mentioned in text, diagrams and technical datasheets has been determined in line with the test conditions described in the standard shown in the heading of this chapter.

Generally, these standardised test conditions will not fully meet the conditions found at the installation site of the system user. Depending on the chosen test method and the extent to which the selected method deviates from the conditions described in the standard shown in the heading of this chapter, any deviations can have a considerable impact. Additional factors that have an influence on the test values are the measuring equipment, the system configuration, the age of the system and the flow rates.

A confirmation of the specified output data can only be obtained if the conditions applicable to the relevant test match those of the standard shown in the heading of this chapter.

2. Safety

2.1 Intended use

The appliance is a decentralised ventilation unit with heat recovery. The appliance is designed for the ventilation of individual rooms or partial ventilation of apartments. The appliance is built into the external wall.

The appliance is intended for domestic use. It can be used safely by untrained persons. The appliance can also be used in non-domestic environments, e.g. in small businesses, as long as it is used in the same way.

Any other use beyond that described shall be deemed inappropriate. Observation of these instructions and of the instructions for any accessories used is also part of the correct use of this appliance.

2.2 Incorrect use

The appliance is not suitable for ventilating rooms with stringent requirements for low germ levels.

The appliance must not be used in systems with aggressive or corrosive gases. The air must be free from hazardous substances.

This appliance is not suitable for drying out buildings.

2.3 General safety instructions

We guarantee trouble-free function and operational reliability only if original accessories and spare parts intended for the appliance are used.



WARNING Injury

The appliance may be used by children over 8 years of age and persons with reduced physical, sensory or mental capabilities or a lack of experience and expertise, provided that they are supervised or they have been instructed on how to use the appliance safely and have understood the potential risks. Children must never play with the appliance. Children must never clean the appliance or perform user maintenance unless they are supervised.



WARNING Injury

If there is a radio or police announcement ordering windows and doors to be kept closed, disconnect the appliance from the power supply.

Close the internal panel if it is not closed.

- ▶ Carefully push the internal panel towards the wall until the internal panel is closed.



WARNING Injury

Operating the appliance with a partially installed fan unit may cause injury or may damage the appliance.



WARNING Injury

The discharged cold air can cause condensation to be formed in the vicinity of the air discharge.

- ▶ Ensure that no risk of slipping due to wet conditions or ice formation occurs on adjacent footpaths and driveways at low temperatures.



Material losses

Operating the appliance during the building/renovation phase may damage the appliance.

Never commission the appliance before the building phase is complete.

2.4 Test symbols

See type plate on the appliance.

3. Appliance description

This appliance works according to the principle of regenerative heat transfer. Heat exchange sections are located in the air flow.

These appliances only function in pairs in alternate operation. One appliance operates for approx. 40 seconds in supply air mode, the other operates simultaneously in extract air mode. The air direction is then changed. This means that the total supply air flow rates is equal to the total extract air flow rates.

In extract air mode, the heat exchanger absorbs the majority of the thermal energy from the extracted indoor air. Once the fan has switched to supply air mode, the heat exchanger transfers the stored thermal energy to the inflowing outdoor air.

A filter outside the building reduces the penetration of dust and other suspended matter. A filter inside the building reduces contamination of the appliance.

4. Settings



Note
When the appliance is in operation, the internal panel must be open.
Never restrict the air flow from the appliance with cupboards, curtains, etc.

4.1 Controls

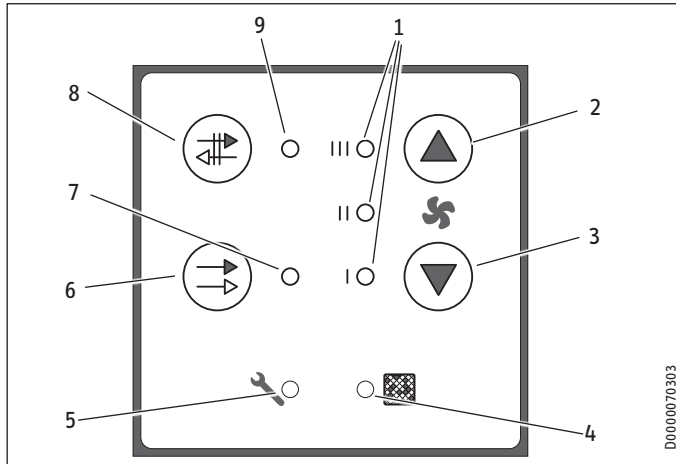

- 1 "Fan stage" indicator
- 2 "UP" button
- 3 "DOWN" button
- 4 "Filter" indicator
- 5 "Fault" indicator
- 6 "Cross-ventilation" button
- 7 "Cross-ventilation" indicator
- 8 "Differential mode" button
- 9 "Differential mode" indicator

4.2 Differential mode

The "Differential mode" button activates the mode that enables the appliance to change the air flow direction at regular intervals.

4.3 Cross-ventilation

The "Cross-ventilation" button activates the mode that enables appliances to operate without heat recovery.

One of the paired appliances permanently draws the extract air from the building. The other appliance permanently draws supply air into the building.

If, on summer nights, the outside temperature is lower than the room temperature, cross-ventilation is ideal for passive cooling of the building.

4.4 Fan stage

	Display	
Ventilation I for humidity protection	I	Necessary ventilation for ensuring that the building structure is protected under normal conditions of use with somewhat reduced moisture loads, e.g. during temporary absence of users and no drying of washing in the residential unit.
Reduced ventilation	II	Reduced ventilation is the ventilation necessary to meet hygiene standards and ensure protection of the building structure (moisture level) under standard conditions of use with partially reduced moisture and pollutant loads, e.g. as a result of intermittent user absence.
Standard ventilation	III	Standard ventilation is the ventilation necessary to meet hygiene standards and ensure protection of the building structure when users are present.
Intensive ventilation	I & II & III	Intensive ventilation is increased ventilation with a higher flow rate to reduce load peaks, e.g. for rapid ventilation during or after a party. Intensive ventilation ends automatically after a time that you set.

- ▶ Set the fan stage using the "UP" and "DOWN" buttons.
- ▶ The selected fan stage is indicated by the three LEDs on the "Fan stage" indicator. When the fan stage is "Intensive ventilation", the three LEDs on the "Fan stage" indicator light up simultaneously.

4.5 Intensive ventilation

To set intensive ventilation, press the "UP" button while standard ventilation is active (LED III lights up).

Setting the duration of intensive ventilation

- ▶ When intensive ventilation is activated, press the "Differential mode" and "Cross-ventilation" buttons simultaneously for at least 3 seconds.

The "Differential mode" indicator flashes rapidly, and the "Cross-ventilation" and "Fault" indicators light up.

- ▶ Set the duration using the "UP" and "DOWN" buttons.

Display	Intensive ventilation duration [minutes]							
	15	30	45	60	75	90	105	Unlimited
III	○	○	○	○	○	☀	●	○
II	○	○	○	☀	●	●	●	○
I	○	☀	●	●	●	●	●	○
Filter	●	●	●	●	●	●	●	☀

Delivered condition: 15 minutes

- ▶ To save the selected value, press the "Differential mode" and "Cross-ventilation" buttons simultaneously.

The appliance illuminates the indicators to show that the selected value has been saved.

4.6 Ventilation pause

You can switch off the appliances for an adjustable time.

- ▶ Use the "DOWN" button to select fan stage I.
- ▶ Press the "DOWN" button once.



Note

If you press the "DOWN" button again during the ventilation pause, this switches off the appliance completely.

During the ventilation pause, LED I or LED II flashes slowly. The LED for the fan stage that the appliance is switching to after the ventilation pause flashes.

Duration of the ventilation pause

- ▶ During the ventilation pause (stage 0), press the "Differential mode" and "Cross-ventilation" buttons simultaneously for at least 3 seconds.

The "Differential mode" and "Cross-ventilation" indicators flash rapidly and the "Fault" indicator lights up.

- ▶ Set the duration using the "UP" and "DOWN" buttons.

Display	Duration [minutes] / Fan stage after the ventilation pause							
	0 Off	30 I	60 I	90 I	120 I	30 II	60 II	90 II
III	○	○	○	○	○	○	☀	●
II	○	○	○	○	☀	●	●	●
I	○	○	☀	●	●	●	●	●
Filter	☀	●	●	●	●	●	●	●

Delivered condition: 60 minutes

- ▶ To save the selected value, press the "Differential mode" and "Cross-ventilation" buttons simultaneously.

Ending the ventilation pause

- ▶ To operate the appliance again with the selected fan stage, press the "UP" button.
- ▶ To switch off the appliance, press "DOWN".

4.7 Filter change interval

- ▶ Press the "Differential mode" and "UP" buttons simultaneously for at least 3 seconds.

The "Differential mode" and "Cross-ventilation" indicators light up and the "Fault" indicator flashes.

- ▶ Set the duration using the "UP" and "DOWN" buttons.

Display	Filter change interval [months]				
	12	9	6	3	Unscheduled filter reset
III	○	○	○	○	○
II	○	○	○	○	☀
I	○	○	☀	●	●
Filter	☀	●	●	●	●

Delivered condition: 6 months

- ▶ To save the selected value, press the "Differential mode" and "Cross-ventilation" buttons simultaneously.

4.8 Brightness of the LED indicators

- ▶ Press the "Cross-ventilation" and "DOWN" buttons simultaneously for at least 3 seconds until all indicators except the "Fault" indicator light up.
- ▶ Set the brightness using the "UP" and "DOWN" buttons.
- ▶ The appliance saves the setting after a few seconds.

4.9 Reading the number of hours run

The number of hours run is shown with the LED indicators, which flash one after another. Count how often each indicator flashes. Indication of hours run starts with the flashing of the "Filter" indicator. An LED flashes every 0.5 seconds. After a pause of 3 seconds, look at the next LED. Once all four LEDs have indicated their number of hours, there is a pause of 5 seconds before the indication of hours run occurs a second time for checking purposes.

Display	Each flash stands for ... hours
Filter	10
I	100
II	1000
III	10000

- ▶ Press the "Cross-ventilation" and "UP" buttons simultaneously for at least 3 seconds.
- ▶ Count the indicator flashes.

5. Cleaning, care and maintenance



WARNING Injury

To ensure that no limbs or objects come into contact with the rotating fan blades, switch off the power supply to the appliance at the building's fuse box.

The appliance control unit is maintenance-free.

5.1 Cleaning

- ▶ Wipe the internal panel with a soft dry cloth.

5.2 Replacing filters

You can buy filters as accessories:

	Filter class	
VLR 70 RF G2	ISO Coarse > 30 % (G2)	Outside
VLR 70 RF F7	ePM ₁ ≥ 50 % (F7)	Inside

After an adjustable number of days run, the "Filter" indicator lights up.

- ▶ When the "Filter" indicator lights up, replace the filters.

We recommend replacing the filters every 6 months. If the ambient air is polluted, replace the filters more often. Check the filters monthly.

OPERATION

Cleaning, care and maintenance

5.2.1 Opening the internal panel

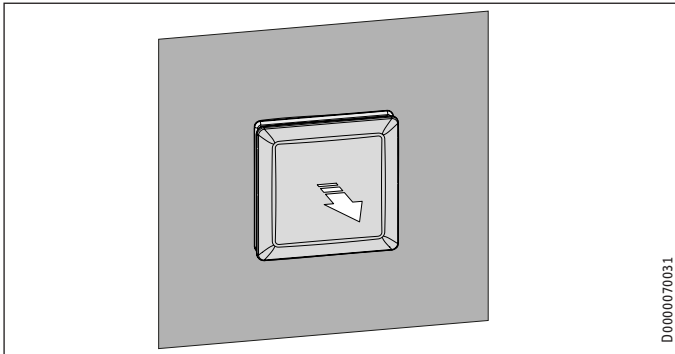

- ▶ If the internal panel is not open, carefully pull the internal panel cover slightly back from the wall.

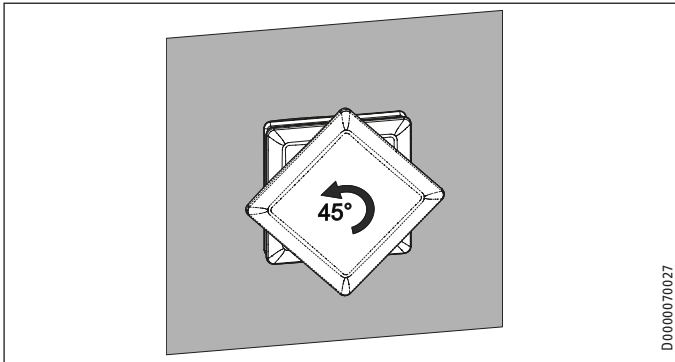

- ▶ Rotate the internal panel cover 45° anti-clockwise.
- ▶ Remove the cover.

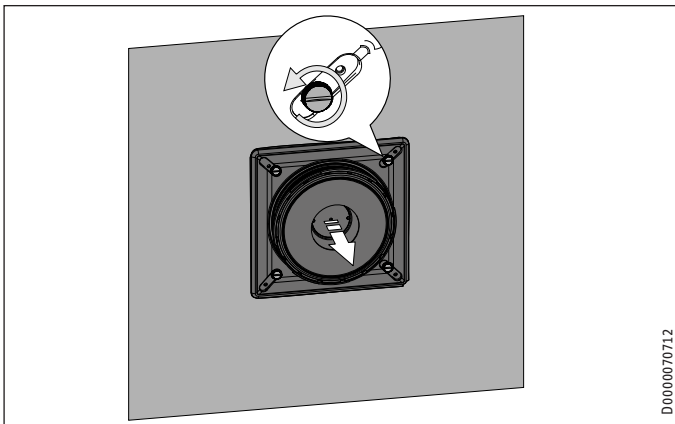

- ▶ Undo the four knurled screws.
- ▶ Remove the internal panel base plate.

5.2.2 Removing the fan unit

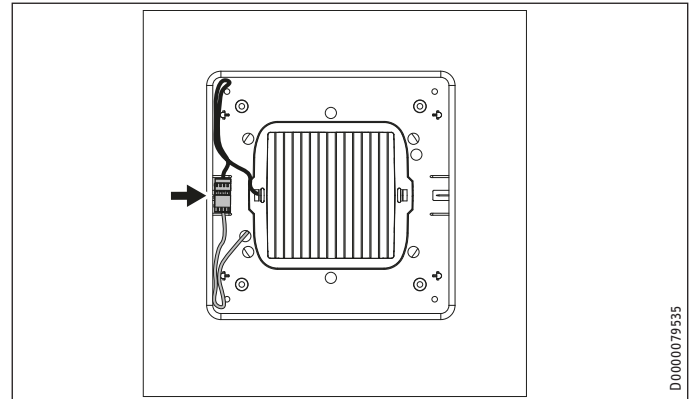

- ▶ Pull the plug-in connection to the right to remove it from the retainer.
- ▶ Disconnect the plug-in connection.

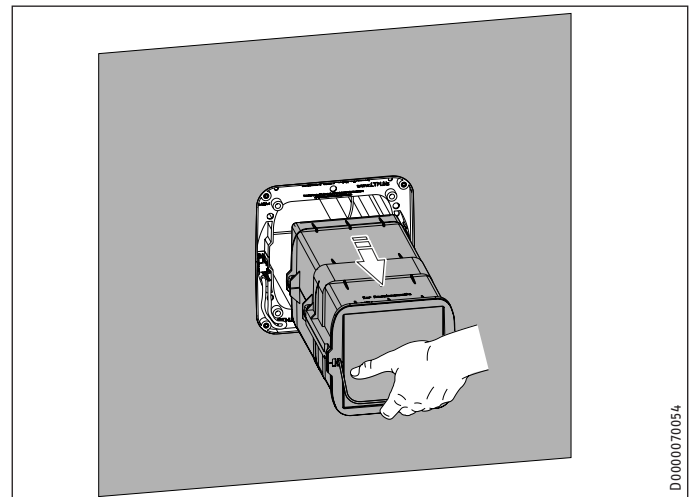

- ▶ Use the bracket to pull the fan unit out of the wall mount casing.

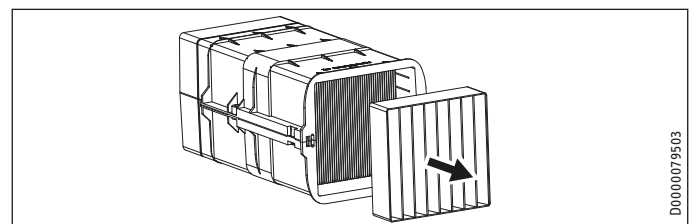

- ▶ Remove the internal filter.

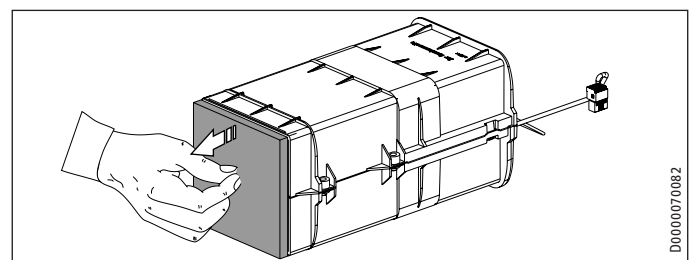

- ▶ Remove the external filter. Use a screwdriver if necessary.
- ▶ Insert new external and internal filters.

Cleaning, care and maintenance

5.2.3 Resetting the filter timer

- ▶ When the "Filter" indicator lights up, press the "Cross-ventilation" and "Differential mode" buttons simultaneously for at least 3 seconds.

The "Filter" indicator goes off.

5.2.4 Logging a filter change

- ▶ Enter the filter change in the filter change report at the back of the instruction manual.

5.3 Cleaning heat exchangers

Clean the appliance's heat exchangers at the start of the heating season. If the ambient air is polluted, clean the heat exchangers every 6 months.

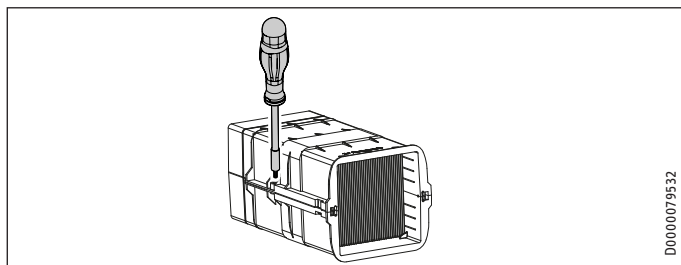

- ▶ Undo the screws on the long sides of the fan unit.

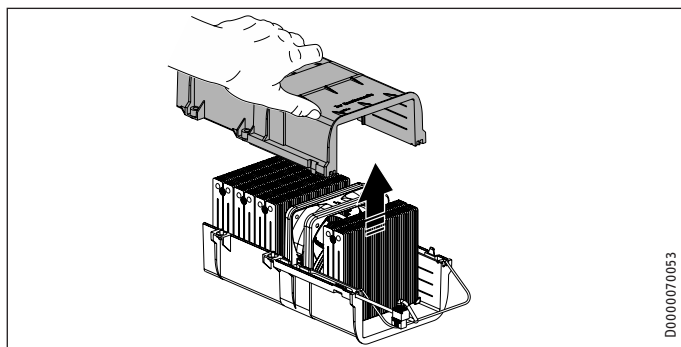

- ▶ Lift off the top half of the fan unit.

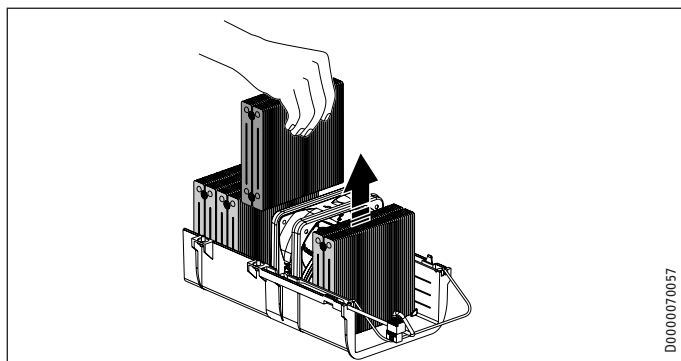

- ▶ Remove the heat exchange sections.

The fan does not need to be removed.

- ▶ Check the fan blades for contamination.
- ▶ Carefully dry-wipe the fan blades if necessary.
- ▶ Carefully clean the fan unit casing with a dry cloth.



Material losses

Never put heat exchangers in the dishwasher. Otherwise, there is a risk of corrosion.

- ▶ Wash the heat exchange sections in warm water with a little washing-up liquid.
- ▶ Leave the heat exchange sections to dry completely before reinstalling them.

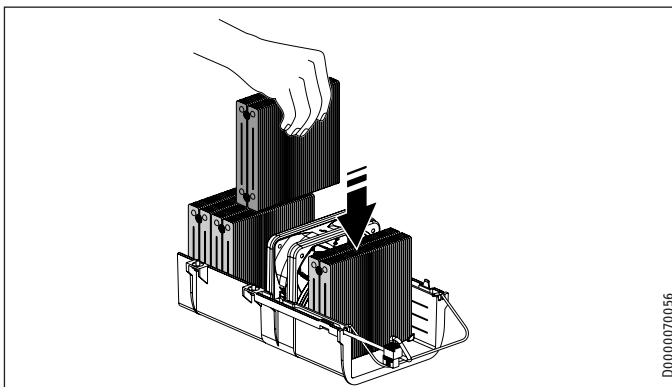

- ▶ Reinsert the heat exchange sections. The fins of the heat exchanger must be vertical.
- ▶ If you removed the fan, ensure that the direction of installation is correct when refitting it. The direction of installation is specified on the fan.
- ▶ Ensure that the gaskets are fitted on the fan.

The fan connecting cable must be routed on the left-hand side in the guide provided.

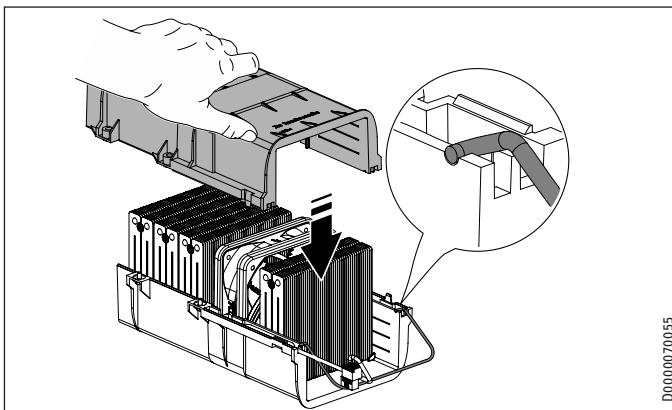

- ▶ Ensure that the bracket is seated correctly in the lower half of the casing.
- ▶ Fit the top half of the fan unit by jiggling it slightly to move it down.

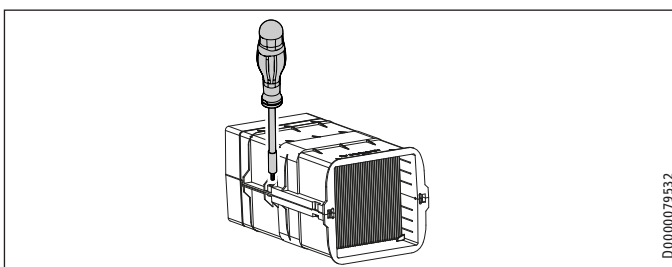

- ▶ Screw in the screws on the long sides of the fan unit.

OPERATION

Cleaning, care and maintenance

5.4 Assembling the appliance



Note

For reasons of hygiene, always replace contaminated filters with new ones. Always use original spare parts. Use of alternative filters may lead to considerable losses of appliance output and functionality.

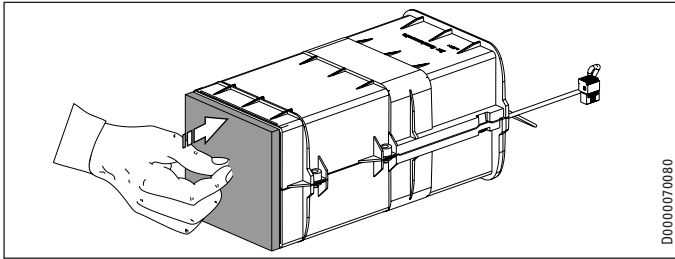

D0000070080

- ▶ Fit a new external filter.

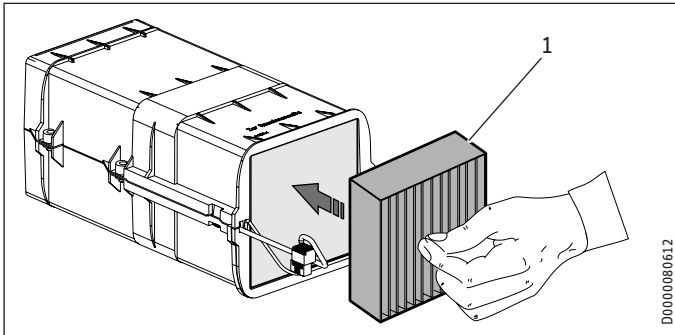

D0000080612

1 Internal filter

- ▶ Fit a new internal filter.

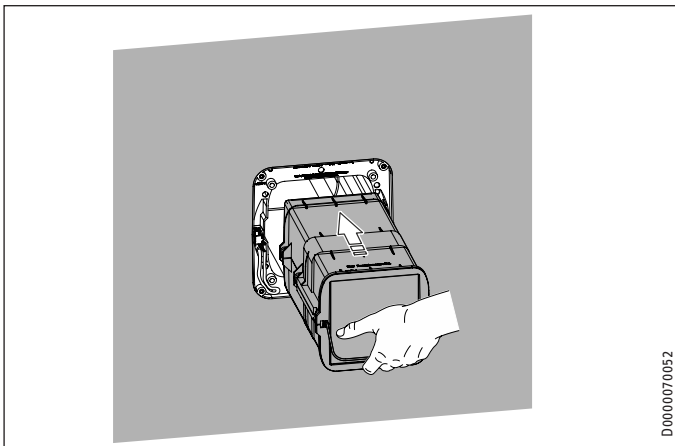

D0000070052

- ▶ Push the fan unit into the wall mount casing so that the bracket is inside the building at the bottom.
- ▶ Ensure that the fan unit is not wedged.
- ▶ Push the fan unit as far as it will go into the wall mount casing.

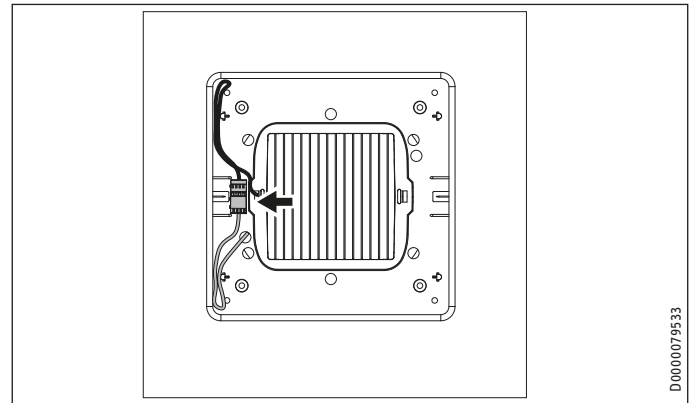

D0000079533

- ▶ Reconnect the power supply.
- ▶ Carefully push the plug-in connection from the right into the retainer.
- ▶ Clamp the cable in a loop underneath the plug-in connection between the plastic bosses.

Internal panel



Material losses

Turn the screws until just finger-tight.

- ▶ Secure the internal panel base plate to the wall mount casing using the four knurled screws.
- ▶ Refit the cover on the internal panel.

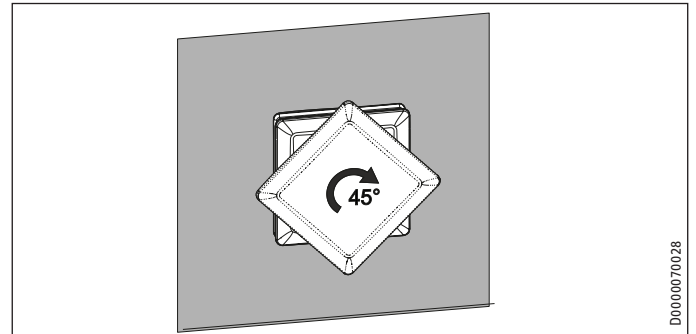

D0000070028

- ▶ Rotate the internal panel cover 45° clockwise.
- ▶ Switch on the power supply to the appliance via the fuse/ MCB in the fuse box.

6. Troubleshooting

If the appliance detects a fault, the "Fault" indicator lights up red.

"Fault" indicator	Cause	Remedy
Flashes 1x	Fan fault	
Flashes 3x	Communication fault	
Flashes continuously	The control unit is not programmed correctly.	See installation instructions.

If you cannot remedy the fault, contact your qualified contractor. To facilitate and speed up your request, provide the number from the type plate (000000-0000-000000).

The type plate can be found on the fan unit after removing the internal panel.

7. Appliance shutdown

- ▶ Switch off the power supply to the appliance via the fuse/ MCB in the fuse box.
- ▶ To prevent heat losses, close the internal panel.

8. Recommissioning

- ▶ Remove the internal panel cover.
- ▶ Fit a new filter.
- ▶ Fit the internal panel cover.
- ▶ Open the internal panel cover.
- ▶ Switch on the power supply.

INSTALLATION

9. Safety

Only a qualified contractor should carry out installation, commissioning, maintenance and repair of the appliance.

9.1 General safety instructions

We guarantee trouble-free function and operational reliability only if original accessories and spare parts intended for the appliance are used.

9.2 Instructions, standards and regulations



Note

Observe all applicable national and regional regulations and instructions.



WARNING Burns

In connection with the fire prevention regulations concerning the installation of ventilation systems, observe all country-specific regulations and requirements.

9.3 Operation of the appliance in buildings with combustion equipment

The term "combustion equipment" used below includes, for example, tiled stoves, fireplaces and equipment with gas combustion.



WARNING Injury

Ventilation units can generate negative pressure in the dwelling. If combustion equipment is operating at the same time, combustion exhaust gases can penetrate the room where the combustion equipment is installed. It is therefore important to observe a number of points for simultaneous operation of a ventilation unit and combustion equipment.

The engineering, installation and operation of the ventilation unit and combustion equipment must be carried out in accordance with national and regional regulations.

9.3.1 Planning safety measures

Together with the relevant authorities, engineers plan the safety measures that are required for simultaneous operation of a ventilation unit and combustion equipment.

Alternate operation

Alternate operation means that, when the combustion equipment is started, the mechanical ventilation system is switched off and/or cannot be started. Alternate operation must be ensured by appropriate measures, e.g. automatically enforced shutdown of the ventilation unit.

Simultaneous operation

For simultaneous operation of combustion equipment and a mechanical ventilation system, we recommend choosing approved room sealed combustion equipment (in Germany, with DIBt approval).

If open flue combustion equipment is operated in the dwelling at the same time as a ventilation unit, combustion exhaust gases must be prevented from penetrating the home as a result of possible negative pressure in the room.

The ventilation unit may only be operated in combination with intrinsically safe combustion equipment. This combustion equipment has, for example, a draught hood or an exhaust gas monitor and is permitted to be operated in conjunction with ventilation units. Alternatively, external, tested safety equipment can be connected to monitor the operation of the combustion equipment. For example, you can install differential pressure monitoring to monitor the chimney draught and to switch off the ventilation unit in the event of a fault.

The equipment for differential pressure monitoring must fulfil the following requirements:

- Monitoring of the differential pressure between the connection piece to the chimney and the room where the combustion equipment is installed
- Possibility of matching the shutdown value for the differential pressure to the minimum draught requirement for the combustion equipment
- Floating contact to switch off the ventilation function
- Optional connection of a temperature capturing device so that differential pressure monitoring is only enabled when the combustion equipment is in operation and so that unwanted shutdowns due to environmental influences can be prevented



Note

Differential pressure switches that use the pressure differential between the outdoor air pressure and the pressure in the room where the combustion equipment is sited as a response criterion are not suitable.



Note

We recommend installing and regularly maintaining a carbon monoxide detector in accordance with EN 50291 for operation of any combustion equipment.

9.3.2 Commissioning

When commissioning the ventilation unit, it is important to check and document in the commissioning log that combustion exhaust gases are not penetrating the dwelling in a quantity that is harmful to health.

Commissioning in Germany

Acceptance is carried out by the local flue gas inspector.

Commissioning outside Germany

Acceptance must be carried out by a specialist. In case of doubt, you must involve an independent expert in the acceptance procedure.

Appliance description

9.3.3 Maintenance

Regular maintenance of the combustion equipment is prescribed. Maintenance includes checking the exhaust gas extraction system, the free pipe cross-sections and the safety equipment. The relevant qualified contractor responsible must prove that is a sufficient flow of combustion air.

10. Appliance description

10.1 Standard delivery

- Tilting wall mount casing with support frame
- Fan unit
- Internal panel
- External panel
- Control set: Programming unit, control unit, flush box, power supply unit subject to the number of appliances

10.2 Accessories

Filter

	Filter class
VLR 70 RF G2	ISO Coarse > 30 % (G2)
VLR 70 RF G4	ISO Coarse > 60 % (G4)
VLR 70 RF M5	ePM ₁₀ ≥ 50 % (M5)
VLR 70 RF F7	ePM ₁ ≥ 50 % (F7)
VLR 70 RF F9	ePM ₁ ≥ 80 % (F9)

PM 2,5 fine dust sensor

- VLR Monitoring accessory

11. Preparation

11.1 Transport



Material losses

Heavy impacts may impair functionality and damage the appliance.

- ▶ Always store and transport the appliance in its delivery packaging.
- ▶ Store the appliance in a dry place protected against vibrations.



Material losses

Leave the appliance in its protective packaging until shortly before installation.

11.2 Installation site



WARNING Electrocutation

If installing the appliance in rooms with a bath and/or shower, take the relevant safety zone into account in accordance with the information on the appliance type plate. The safety zones are defined in the IEC 60364-7-701 standard.

If a pair of appliances working in differential mode are being installed in two different rooms in the apartment, create an air

connection between these rooms by ensuring that the overflow air apertures are large enough.

Windowless extract air areas (e.g. kitchens, bathrooms and toilets) should only be ventilated with the appliance if it is installed in an external wall. Appliances should not be connected to a shaft or pipeline.

To avoid draughts caused by fan operation, we recommend installing the appliance next to windows at lintel height.

Wall thickness including render/plaster

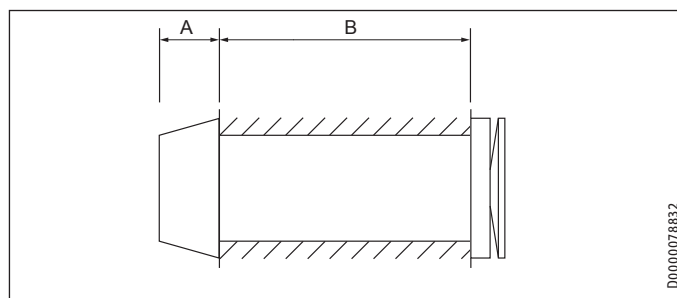

		VLR 70 L Trend EN	VLR 70 S Trend EN
A	mm	80	200
B	mm	300-550	100-300

Minimum clearances

- Ensure a clearance of 350 mm between the side of the internal panel and any furniture.
- Inside the building, ensure there is enough free space in front of the internal panel for inserting and removing the fan unit.
- Never install the appliance near seating areas or at the head of a bed.
- Ensure a clearance of 100 mm from all sides of the external panel to downpipes, balconies and other solid objects.

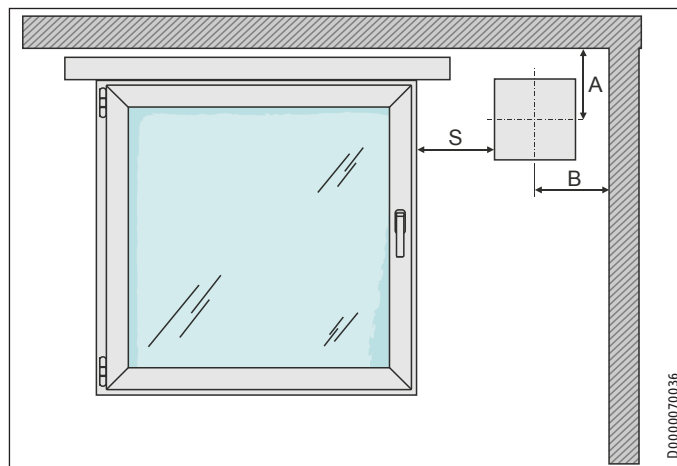

- A 220 mm
- B 220 mm
- S Specified clearance depending on the structural condition of the wall

We recommend positioning the upper edge of the wall outlet 30 mm beneath the upper edge of the window.

INSTALLATION

Preparation

Clearances between appliances working in differential mode

Appliances working as a pair in differential mode must be installed with a minimum horizontal and vertical clearance.

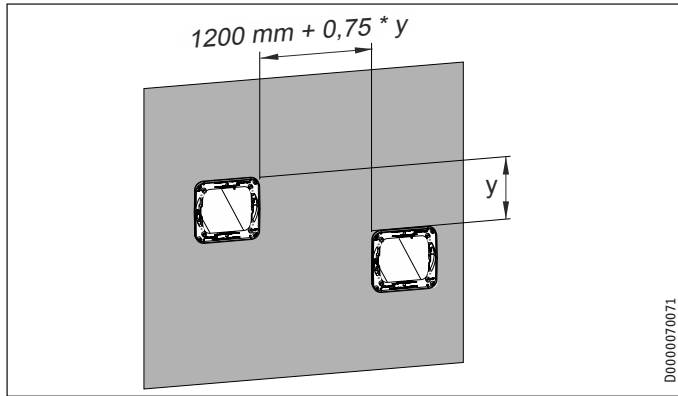

D0000070071

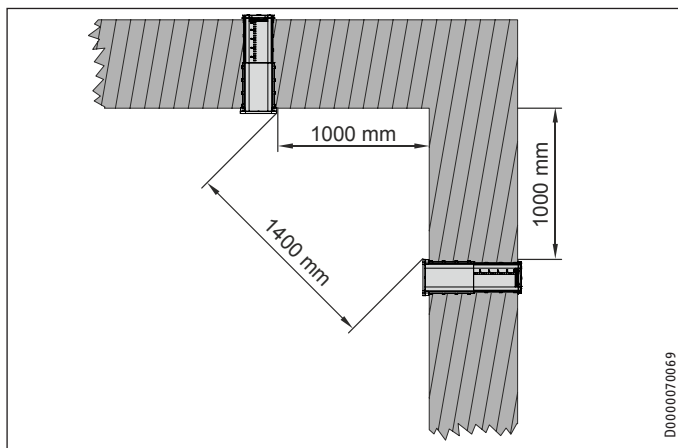

D0000070069

11.3 Wall outlet

The figures show the wall without plaster.

11.3.1 Solid wall

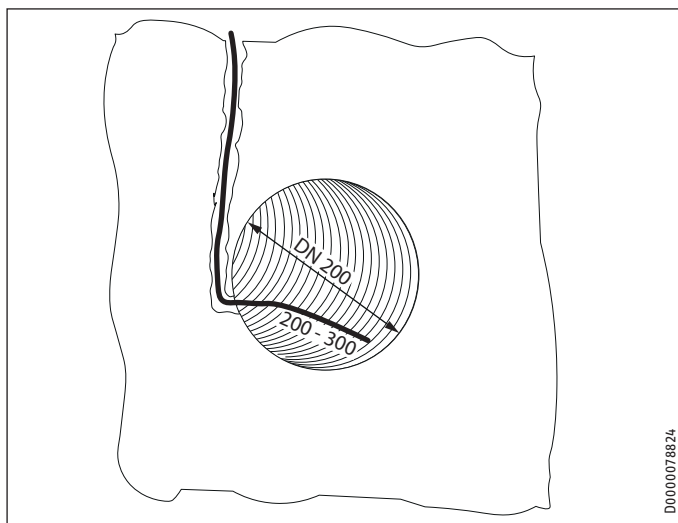

D0000078824

Alternative:

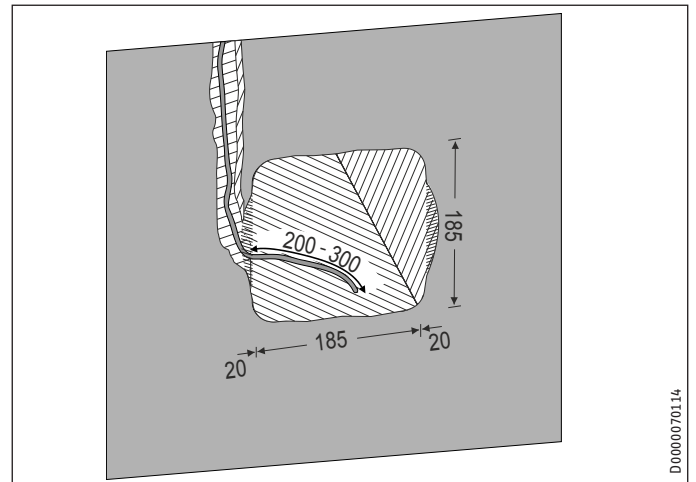

D0000070114

- Create a wall outlet vertical to the wall without a fall.

The fall required for draining any condensate is achieved by securing the wall mount casing on the support frame in such a way that it can be tilted.

- On the inside of the wall, create the slot for the cable, which you route from the control unit to the left-hand side of the wall mount casing. The diagram shows a sample installation where the cable is routed from above. You can also route the cable from below or horizontally to the left-hand side of the wall mount casing.
- Install the cable from the planned installation site of the control unit to the left-hand side of the wall mount casing. The cable must have a free end of 200 to 300 mm in the wall mount casing to enable you to connect the appliance.

Cable type: YR 4 x 0.8 mm² or equivalent

Cable length: ≤ 25 m

11.3.2 Cavity wall installation

- Create a wall outlet vertical to the wall without a fall.

The fall required for draining any condensate is achieved by securing the wall mount casing on the support frame in such a way that it can be tilted.

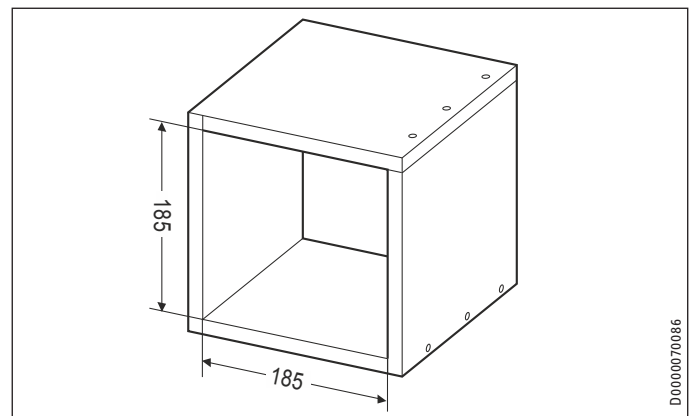

D0000070086

- For a cavity wall, construct enclosed wooden edging with a length corresponding to the wall thickness between the internal lining and external cladding.

INSTALLATION

Preparation

- ▶ Install the cable from the planned installation site of the control unit to the left-hand side of the wall mount casing. The cable must have a free end of 200 to 300 mm in the wall mount casing to enable you to connect the appliance.

Cable type: YR 4 x 0.8 mm² or equivalent

Cable length: ≤ 25 m

- ▶ Drill a hole with a diameter to fit the cable, to create a cable entry in the wooden edging.
- ▶ Route the cable through the hole.

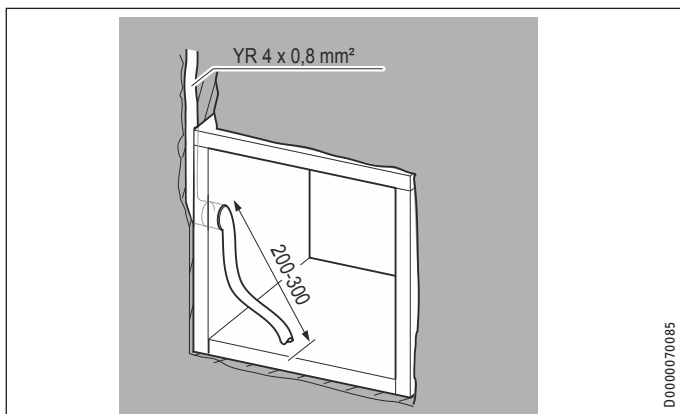

- ▶ Secure the wooden edging in the aperture. Use PUR foam, for example.

11.4 Control unit and programming unit

- ▶ Select a suitable, easily accessible location for mounting the programming unit on the wall.

11.5 Power supply unit

Power supply unit for 2 appliances

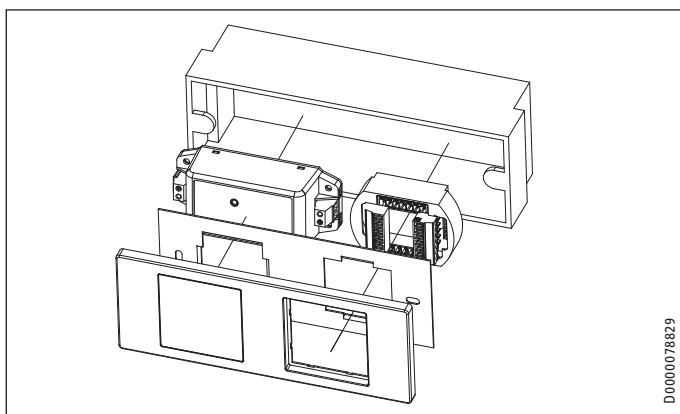

The control unit, the power supply unit and the programming unit are installed together in a double flush box.

- ▶ Mount the double flush box included as part of the standard delivery. The flush box must be vertical and flush with the interior plaster.
- ▶ Push the cable routed to the ventilation unit into the flush box. The cable must protrude 200 mm into the flush box.
- ▶ Push the power cable into the flush box. The cable must protrude 200 mm into the flush box.

Power supply unit for more than 2 appliances

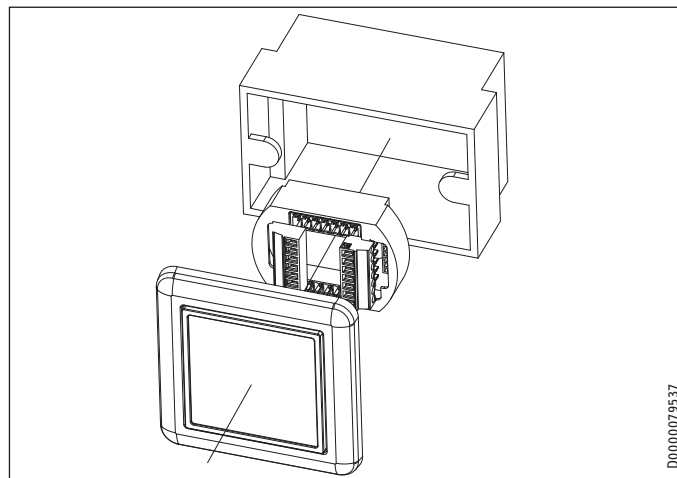

The control unit and the programming unit are installed in a flush box. The power supply unit is installed on a top-hat rail in the fuse box. The power supply unit requires up to 4 MCB spaces.

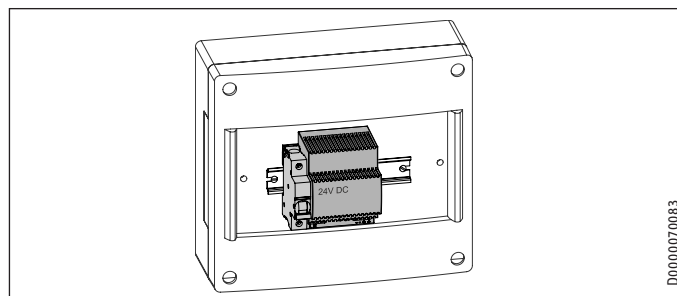

- ▶ Install the power supply unit on a top-hat rail in the control panel fuse box.
- ▶ Mount the flush box for installing the control unit and programming unit. The flush box must be vertical and flush with the interior plaster.
- ▶ Install the cable from the control panel to the control unit.

Cable type: YR 4 x 0.8 mm² or equivalent

Cable length: ≤ 25 m

- ▶ Push the cable routed to the control panel into the flush box. The cable must protrude 200 mm into the flush box.
- ▶ Push the cable routed to the ventilation unit into the flush box. The cable must protrude 200 mm into the flush box.

12. Installation

12.1 Wall mount casing

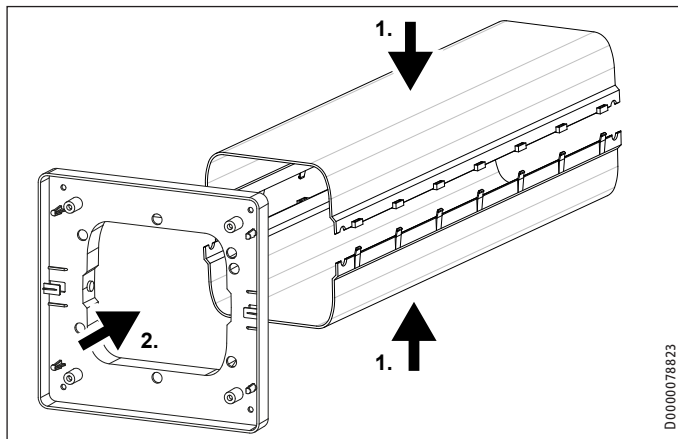

D0000078823

- ▶ Place the two halves of the wall mount casing together.
- ▶ Carefully push the support frame into the wall mount casing. The round brackets at the side must click into place in the apertures of the wall mount casing.

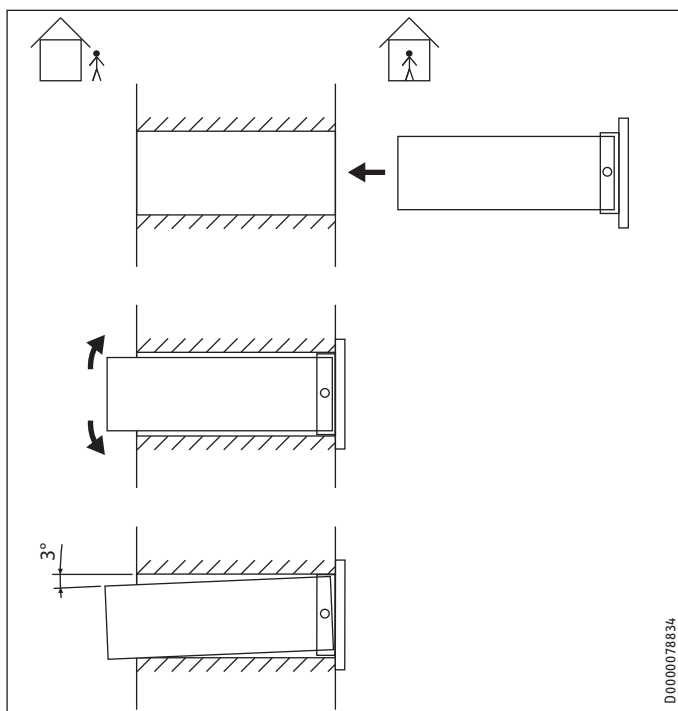

D0000078834



Material losses

The joint between the two halves of the wall mount casing must not be facing down. Otherwise, condensate may escape and penetrate the wall.

- ▶ On the inside of the building, push the wall mount casing almost all the way into the wall.

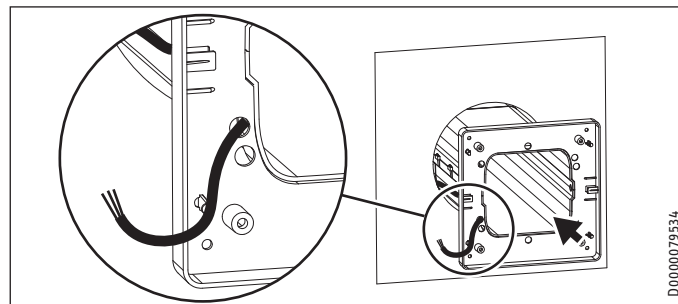

D0000079534

- ▶ On the left-hand side of the wall mount casing, route the cable from the back through the cable entry.
- ▶ Push the wall mount casing all the way into the wall.

When you push the support frame on the internal wall upwards, a fall is created in the wall mount casing as a result of the axis bracket. Any condensate that occurs can run outside the building.

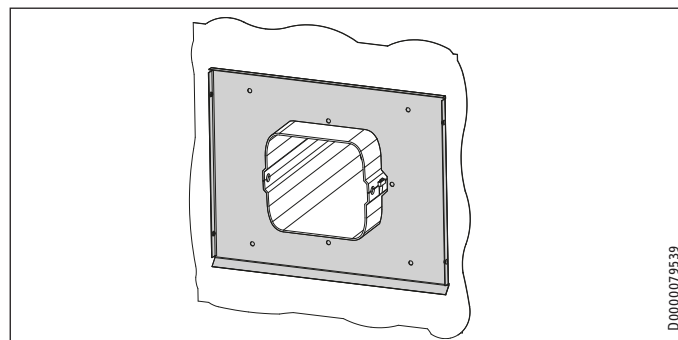

D0000079539

- ▶ On the outside of the building, push the external cover base plate over the wall mount casing protruding from the wall.

VLR 70 S Trend EN: Shortening the wall mount casing



Material losses

With this appliance, you can only shorten the wall mount casing up to the marker. This is the marker for positioning the fan and heat exchanger inside the wall mount casing at a later date.

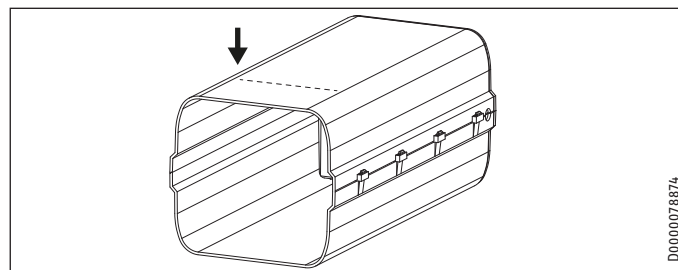

D0000078874

- ▶ Shorten the wall mount casing so that it protrudes over the external panel base plate by the length illustrated.

INSTALLATION

Installation

VLR 70 L Trend EN: Shortening the wall mount casing

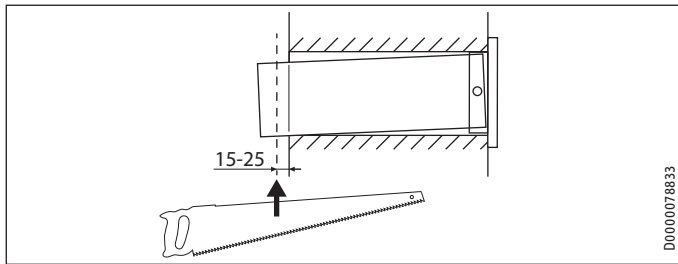

- ▶ Shorten the wall mount casing so that it protrudes over the external panel base plate by the length illustrated.

Securing the wall mount casing to the inside of the building

- ▶ Align the wall mount casing centrally in the wall aperture so that the apertures for injecting the PUR foam are not blocked by the brickwork.

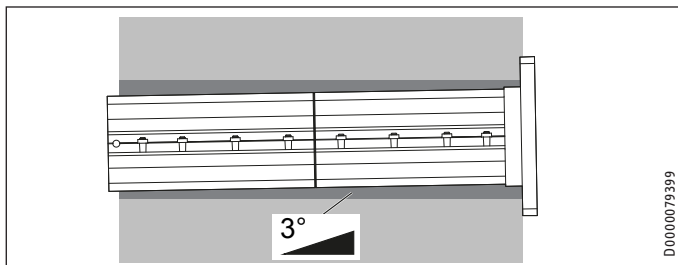

! Material losses

To prevent condensate from running into the building, the wall mount casing must be mounted with a slight external fall. An internal fall can cause damage due to damp in the building.

- ▶ Push the support frame for the wall mount casing upwards as far as it will go.

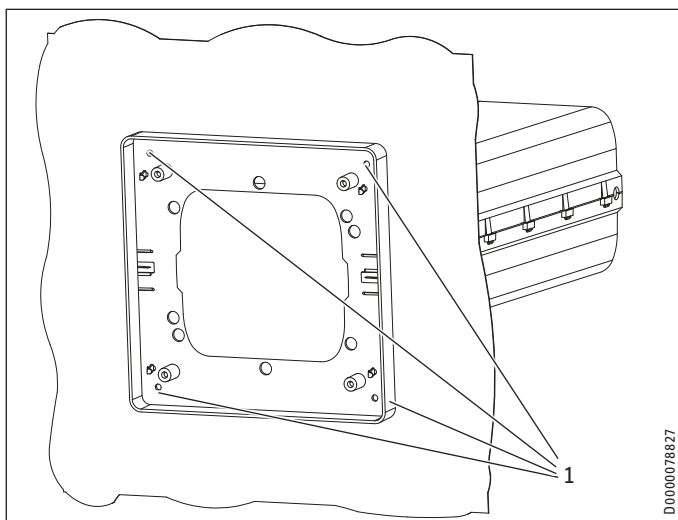

- 1 Hole for securing the wall mount casing
- ▶ Align the wall mount casing horizontally.
 - ▶ Mark the fixing points where you will be securing the wall mount casing to the internal wall of the building.
 - ▶ Drill holes at the fixing points.
 - ▶ Screw the wall mount casing to the wall at the fixing points.

12.2 Securing the external cover base plate

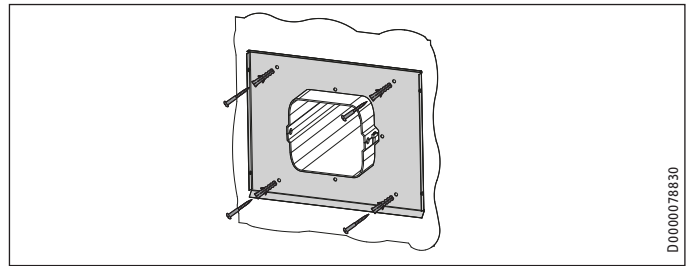

- ▶ Secure the base plate to the wall with four screws.

12.3 Foaming

Support elements

You can use the EPS support element included in the standard delivery to support the wall mount casing from the inside, before applying foam around the outside of the wall mount casing.

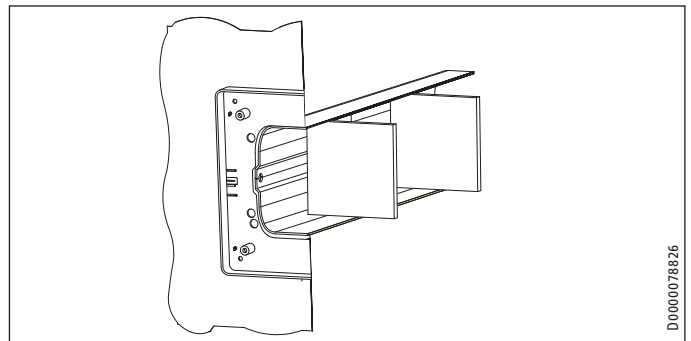

	VLR 70 S Trend EN	VLR 70 L Trend EN
Number of support elements	2	3

- ▶ Install the support elements in the wall mount casing so that they are evenly distributed along its length. The support elements prevent the wall mount casing from becoming compressed during foaming.

! Material losses

Only remove the support elements just before you push the appliance into the wall mount casing. The support elements protect the wall mount casing. The support element prevents draught.

PUR foam

! Material losses

Only use rigid 2-component PUR foam.

Note

Observe the instructions for the PUR foam. To increase the foam volume, you may need to moisten the substrate.

INSTALLATION

Installation

Inside

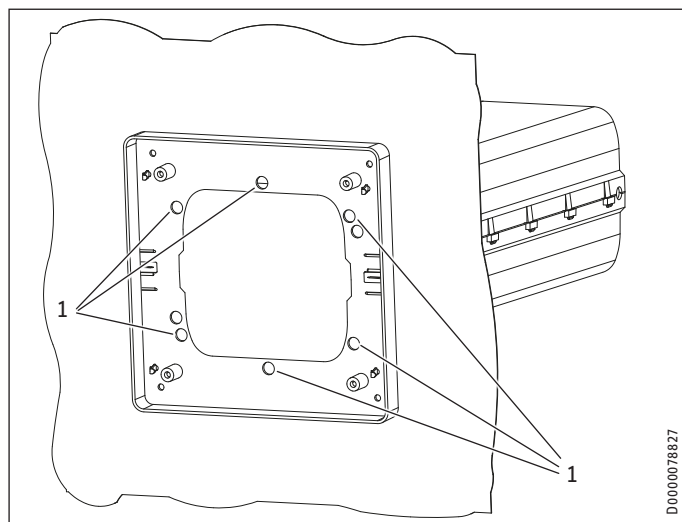

1 Apertures for foaming

- Foam the spaces around the wall mount casing to the entire wall thickness.

Outside

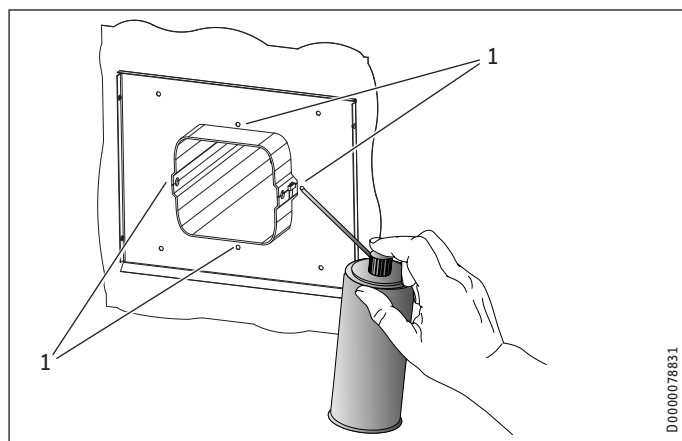

1 Apertures for foaming

- Foam around the wall mount casing through the apertures on the outside of the building.

12.4 Sealing off

- Once the PUR foam has hardened, trim off any bits of protruding foam.

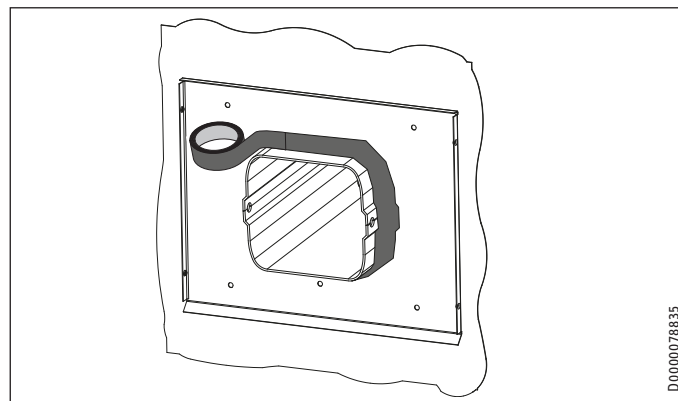

- Affix the permeable film as a vapour barrier to the outside over the joint between the wall mount casing and the external cover base plate.

12.5 Insulating the wall mount casing

- Insulate the part of the wall mount casing protruding from the wall.

12.6 Sealing the external cover base plate

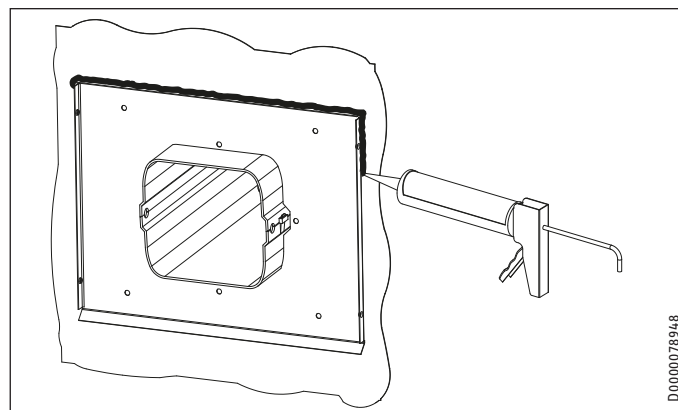

- Use a permanently elastic sealant to seal the joint between the external panel base plate and the wall.

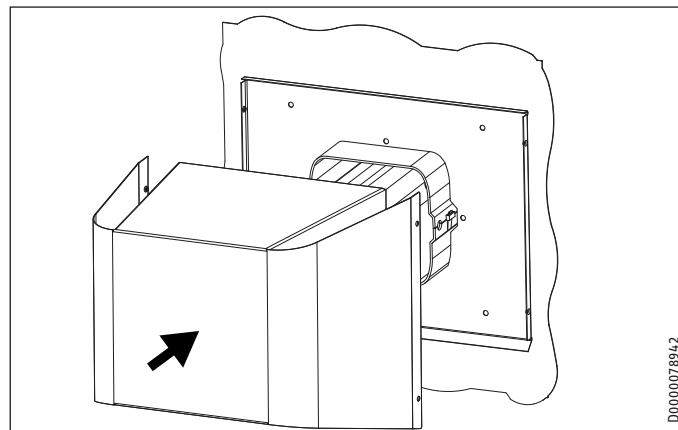

INSTALLATION

Installation

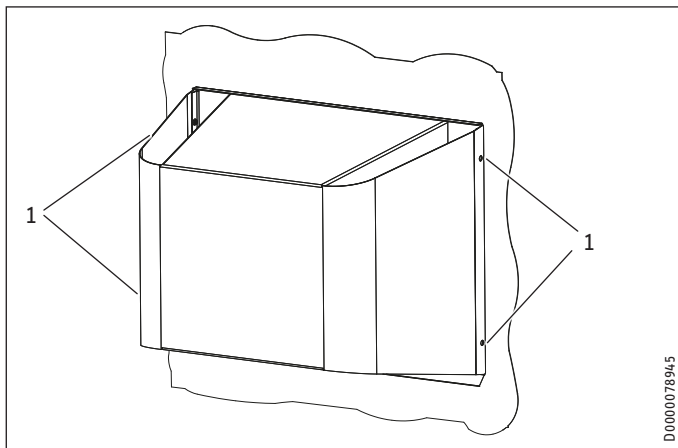

- 1 Screws for securing the external cover to the base plate
 ▶ Secure the external cover to the base plate.

12.7 Electrical connection



WARNING Electrocutation
 Only qualified electricians may carry out the connection in accordance with these instructions. Carry out all electrical connection and installation work in accordance with national and regional regulations.



WARNING Electrocutation
 The connection to the power supply must be in the form of a permanent connection. Ensure the appliance can be separated from the power supply by an isolator that disconnects all poles with at least 3 mm contact separation. This requirement can be met by using contactors, circuit breakers, fuses/MCBs, etc.



WARNING Electrocutation
 Before working on the electrical installation, disconnect the circuit from the power supply. Switch off the fuse/MCB in the fuse box.



Material losses
 The specified voltage must match the mains voltage. Observe the type plate.

Observe the fuse protection required for the appliance (see chapter "Specification / Data table").

12.7.1 Wiring diagram with more than 2 appliances

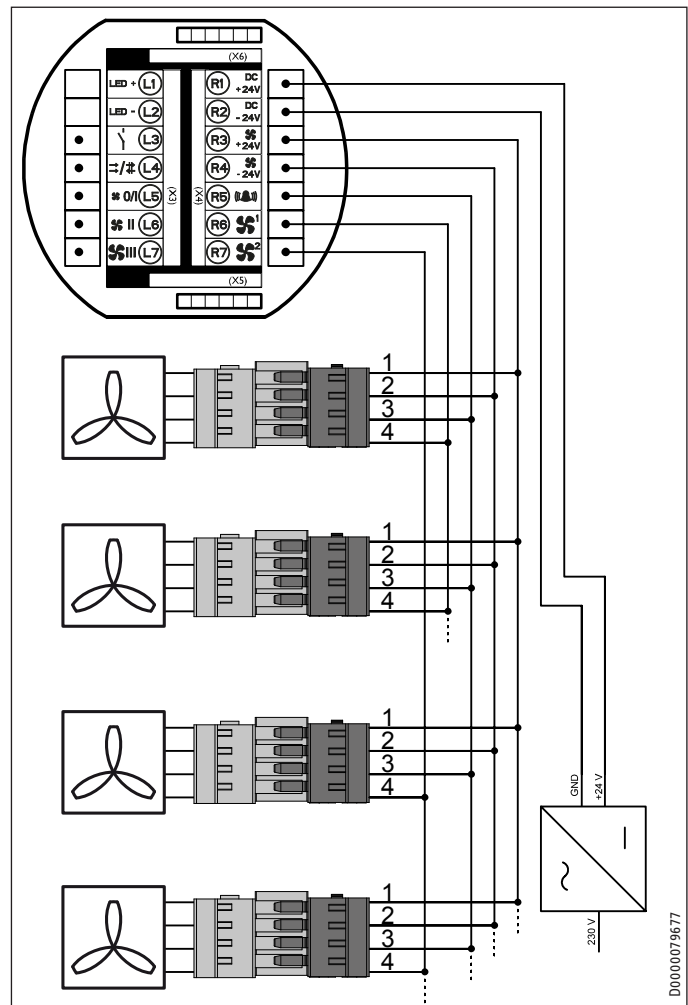

R1	DC +24 V
R2	DC -24 V
R3	Fan +24 V
R4	Fan -24 V
R5	Alarm
R6	Fan 1
R7	Fan 2

- ▶ Assign the appliances to the "Fan 1" and "Fan 2" terminals. Of the pair of appliances working in differential mode, one must be connected to the "Fan 1" terminal and the other must be connected to the "Fan 2" terminal. Check whether the pairs of appliances are working in differential mode. In differential mode, one appliance transports the extract air out of the building to the outside. The other appliance draws outdoor air into the building.

Odd number of appliances

If there is an odd number, divide the appliances into two groups. Connect the smaller group to the "Fan 1" terminal.

Number of fans	3	5	7
Number of appliances at "Fan 1" terminal	1	2	3
Number of appliances at "Fan 2" terminal	2	3	4

INSTALLATION

Installation

12.7.2 Wiring diagram with 2 appliances

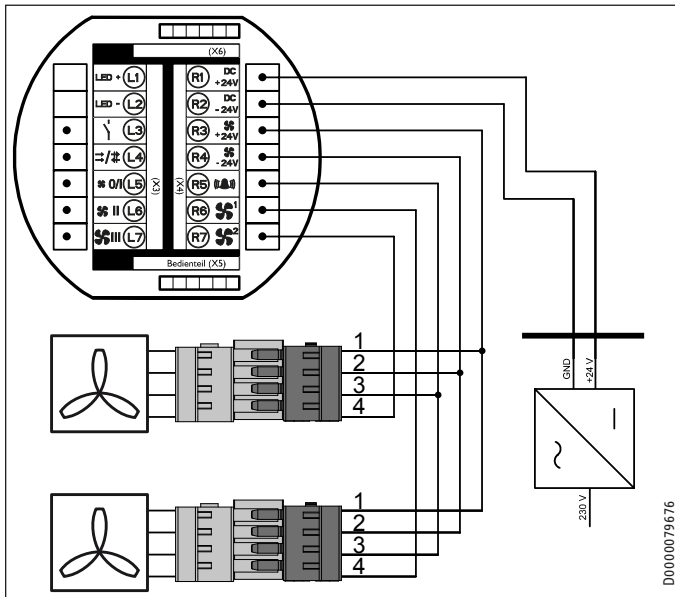

R1	DC +24 V
R2	DC -24 V
R3	Fan +24 V
R4	Fan -24 V
R5	Alarm
R6	Fan 1
R7	Fan 2

12.7.3 Connecting the plug-in connection to the control unit cable

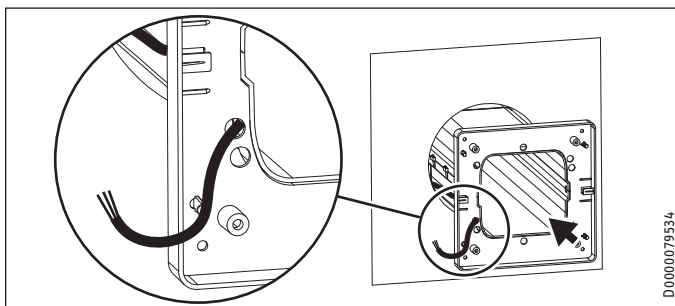

- ▶ Remove a 30 mm length from the cable sheath.
- ▶ Strip the cable wires to a length of 10 mm.
- ▶ Use a pointed object to open the plug-in connection terminal. Insert the cable wires.

12.7.4 Control unit and power supply unit



Material losses

Interchanging the connections may result in control unit malfunctions.



Note

When using a differential pressure switch, always interrupt the power supply to the control unit or power supply unit.

Power supply unit for 2 appliances

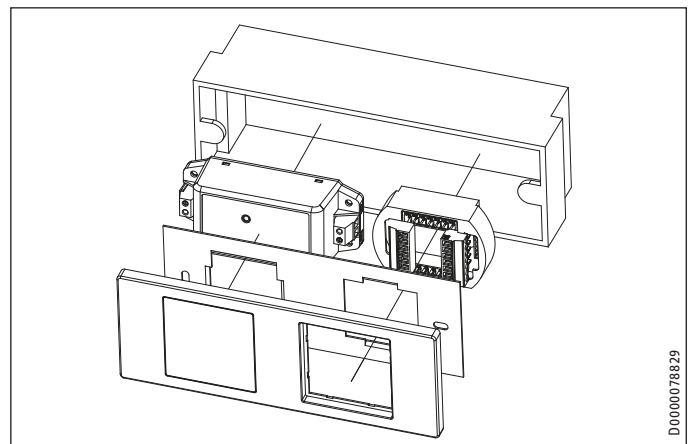

- ▶ Install the power supply unit in the flush box.
- ▶ Install the control unit in the flush box.
- ▶ Connect the control unit to the power supply unit as per the wiring diagram.
- ▶ Observe the imprint on the control unit.

Power supply unit for more than 2 appliances

- ▶ Connect a dedicated MCB upstream of the power supply unit installed in the control panel.

The wiring from the control panel to the appliances is carried out in a star pattern.

- ▶ Install the control unit in the flush box.
- ▶ Connect the control unit to the power supply unit as per the wiring diagram.
- ▶ Observe the imprint on the control unit.

INSTALLATION

Installation

12.7.5 Activation of fan stages by means of an external signal

You can use sensors with potential-free N/O or changeover contacts. Only one of the versions shown should be connected.

Cross-ventilation

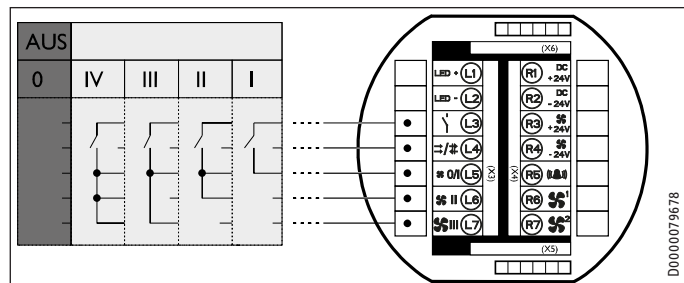

Differential mode

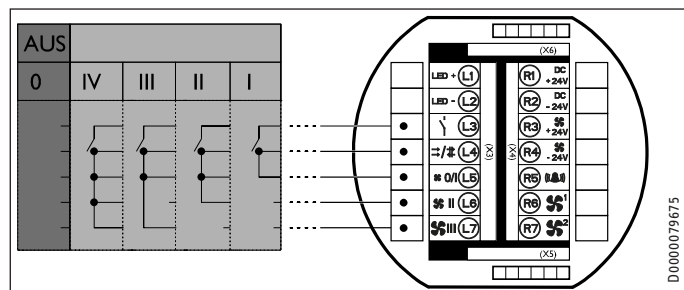

L1	LED+
L2	LED-
L3	Switch
L4	Operating mode
L5	Fan stage 0/I
L6	Fan stage II
L7	Fan stage III

12.7.6 Connecting the programming unit to the control unit

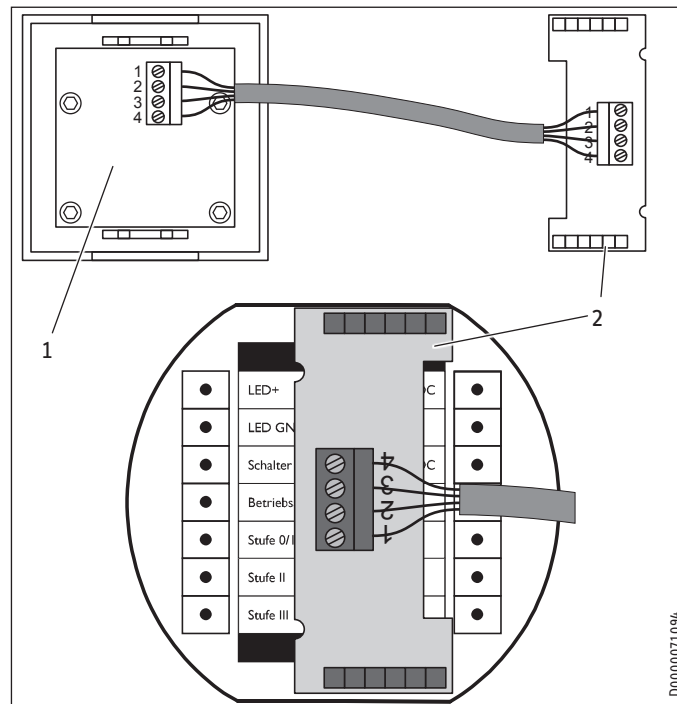

12.8 Installing the programming unit



Note

Before installing the programming unit, the wiring between the control unit and fan and between the control unit and power source must be complete.

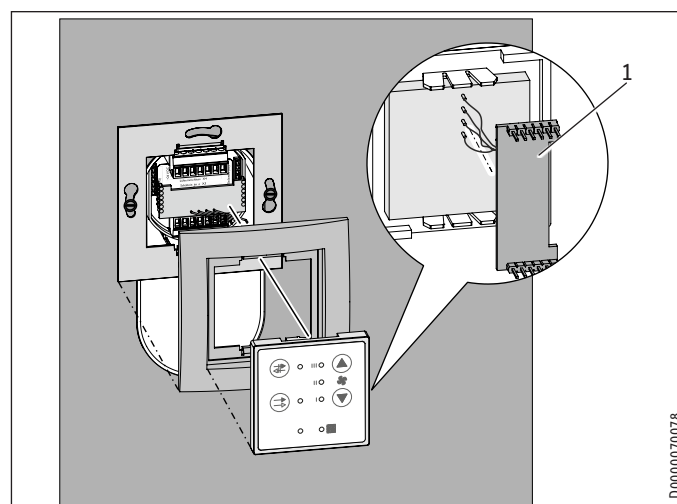

1 Adaptor board

- ▶ Pass the adaptor board through the cover frame and the plate frame. The short tabs on the plate frame must point towards the wall.
- ▶ Position the adaptor board on the control unit so that the terminal strips are not covered.

INSTALLATION

Installation



Note

The existing cable between the adaptor board and the programming unit must not be extended.

- ▶ Screw the plate frame onto the flush box. The tabs must be facing up and down.
- ▶ Position the cover frame on the plate frame.
- ▶ Place the programming unit in the cover frame aperture. Carefully push the programming unit until it clicks into place in the plate frame.

12.9 Installing the fan unit

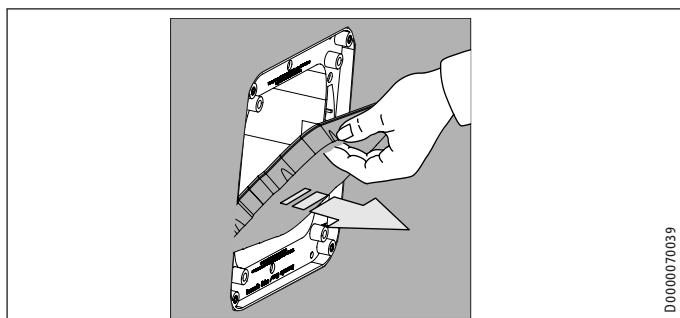

- ▶ Remove the support elements from the wall mount casing.
- ▶ Clean the wall mount casing.

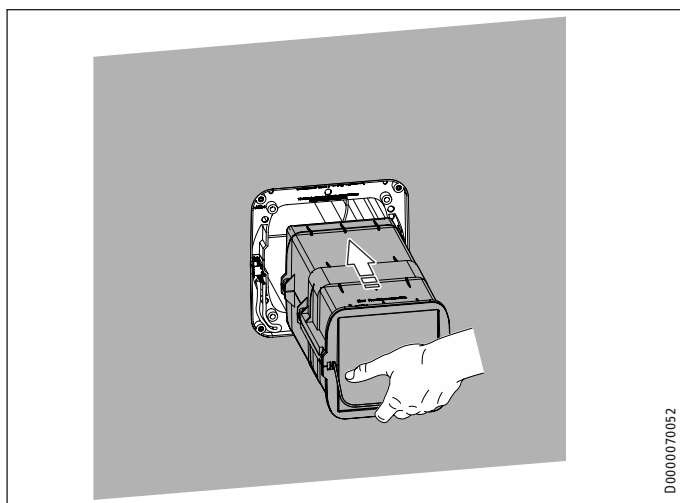

- ▶ Push the fan unit into the wall mount casing so that the bracket is inside the building at the bottom.
- ▶ Ensure that the fan unit is not wedged.
- ▶ Push the fan unit as far as it will go into the wall mount casing.
- ▶ Plug the fan unit plug into the plug-in connection.

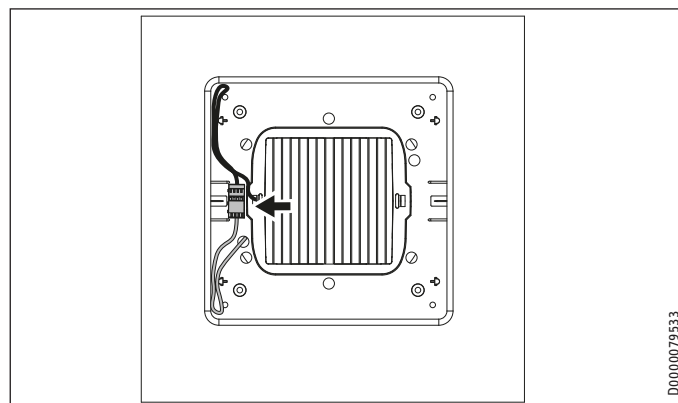

- ▶ Carefully push the plug-in connection from the right into the retainer.
- ▶ Clamp the cable in a loop underneath the plug-in connection between the plastic bosses.

12.10 Installing the internal panel

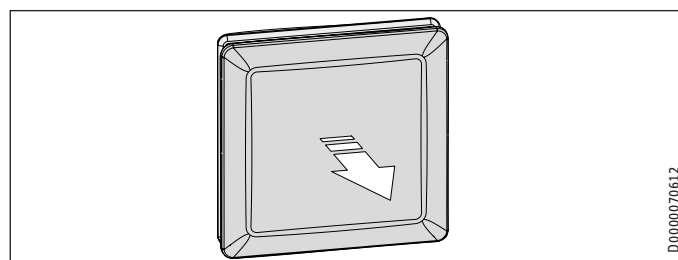

- ▶ If the internal panel is not open, carefully pull the internal panel cover slightly back from the base plate.

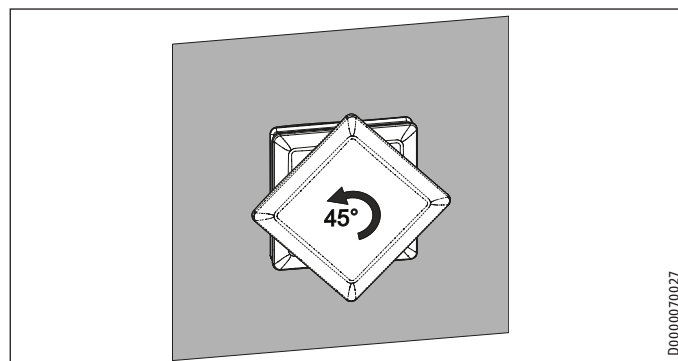

- ▶ Rotate the internal panel cover 45° anti-clockwise.
- ▶ Remove the cover.

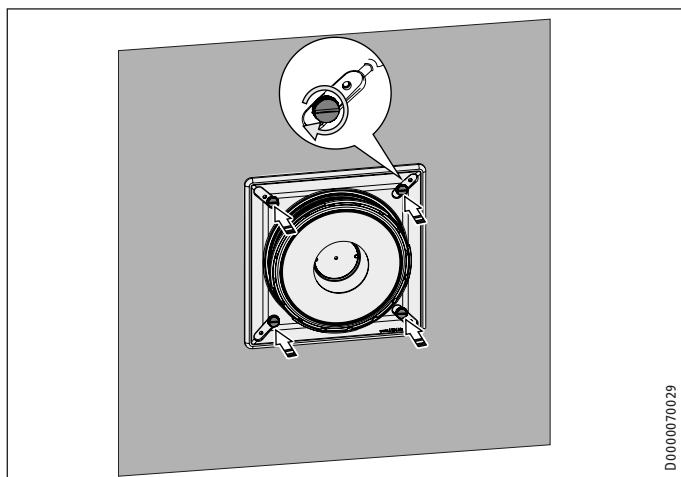

D0000070029

- ▶ Use the knurled screws included in the standard delivery to secure the internal panel base plate to the wall mount casing.

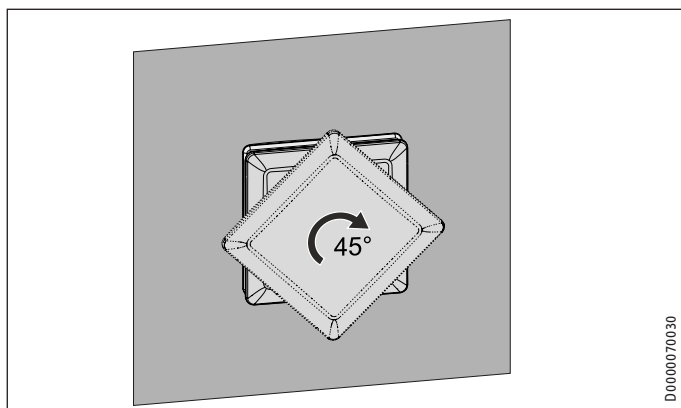

D0000070030

- ▶ Fit the internal panel cover on the base plate with a 45° offset.
- ▶ Rotate the internal panel cover 45° clockwise.
- ▶ Close the internal panel by carefully pressing the cover onto the base plate.



Note

Only open the internal panel just before commissioning.

13. Commissioning

13.1 Initial start-up

13.1.1 Checks before commissioning

All electrical cables must be installed correctly by a qualified contractor.

The fan must be able to rotate freely. There should not be any obstructions in the area of the fan.

13.1.2 Opening the internal panel

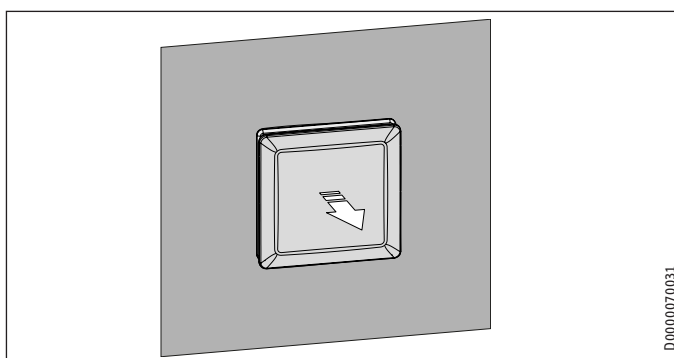

D0000070031

- ▶ Carefully pull the internal panel cover slightly back from the wall.

13.1.3 Switching on the power supply

- ▶ Switch on the power supply to the appliance via the fuse/ MCB in the fuse box.

13.1.4 Programming the control unit

First, you need to select the number of appliances connected to the control unit.

- ▶ Press and hold down the 4 buttons on the programming unit simultaneously for more than 5 seconds until the two operating mode indicators light up.

Display	Number of appliances							
	2	3	4	5	6	7	8	
III	<input type="radio"/>	<input type="radio"/>	<input type="radio"/>	<input type="radio"/>	<input type="radio"/>	<input type="radio"/>	<input type="radio"/>	
II	<input type="radio"/>	<input type="radio"/>	<input type="radio"/>	<input type="radio"/>	<input type="radio"/>	<input type="radio"/>	<input type="radio"/>	
I	<input type="radio"/>	<input type="radio"/>	<input type="radio"/>	<input checked="" type="radio"/>	<input type="radio"/>	<input checked="" type="radio"/>	<input type="radio"/>	
Filter	<input checked="" type="radio"/>	<input checked="" type="radio"/>	<input checked="" type="radio"/>	<input checked="" type="radio"/>	<input checked="" type="radio"/>	<input checked="" type="radio"/>	<input checked="" type="radio"/>	

- ▶ Set the number of connected appliances using the "UP" and "DOWN" buttons.
- ▶ Press the "Differential mode" and "Cross-ventilation" buttons simultaneously for at least 3 seconds.
- ▶ All programming unit indicators light up briefly. The appliances and the programming unit are then ready for operation.
- ▶ Check the appliance functions.

13.2 Recommissioning

- ▶ Open the internal panel.

- ▶ If the fan unit has been removed and the wall mount casing is filled with insulation material, remove the insulation material.
- ▶ Push the fan unit into the wall mount casing so that the bracket is inside the building at the bottom.

14. Settings

14.1 Scanning software/hardware statuses

- ▶ Press the "UP" and "DOWN" buttons simultaneously for at least 3 seconds.

When the "Fault" indicator lights up, you can select scan mode.

Display	Scan mode Control unit software	Control unit hardware	Program- ming unit software	Program- ming unit hardware
III	<input type="radio"/>	<input type="radio"/>	<input type="radio"/>	<input type="radio"/>
II	<input type="radio"/>	<input type="radio"/>	<input type="radio"/>	<input checked="" type="radio"/>
I	<input type="radio"/>	<input checked="" type="radio"/>	<input checked="" type="radio"/>	<input checked="" type="radio"/>
Filter	<input checked="" type="radio"/>	<input checked="" type="radio"/>	<input checked="" type="radio"/>	<input checked="" type="radio"/>

- ▶ Select the information you wish to scan for using the "UP" and "DOWN" buttons.

The "Fault" indicator flashes 7 times in rapid succession.

- ▶ Count how often the "Cross-ventilation" indicator flashes. This number is the first digit of the software/hardware status.

The "Fault" indicator flashes once.

- ▶ Count how often the "Cross-ventilation" indicator flashes. This number is the second digit of the software/hardware status.

The "Fault" indicator flashes once.

- ▶ Count how often the "Cross-ventilation" indicator flashes. This number is the third digit of the software/hardware status.

To enable you to check the information that is displayed, the flashing sequence is repeated three times.

15. Appliance shutdown

15.1 Temporary shutdown

- ▶ Switch off the power supply to the appliance via the fuse/ MCB in the fuse box.
- ▶ To prevent heat losses, close the internal panel.

15.2 Shutdown for a prolonged period

- ▶ Remove the internal panel.
- ▶ Use the bracket to pull the fan unit out of the wall mount casing.
- ▶ Fill the wall mount casing with insulation material. This makes it easier to install a new appliance later on.
- ▶ Close the internal panel.

16. Specification

		VLR 70 S Trend EN	VLR 70 L Trend EN
		200002	201458
Sound emissions			
Sound power level L_{WA} relative to air flow rate	dB(A)	35 (at 20 m ³ /h)	35 (at 20 m ³ /h)
Application limits			
Operating temperature range	°C	-15 to +40	-15 to +40
Electrical data			
Power consumption, ventilation	W	7	7
Rated voltage	V	24	24
Max. current consumption	A	0.3	0.3
Max. power consumption	W	7	7
Versions			
Filter class		ePM1 ≥ 50 % (F7) ISO Coarse > 30 % (G2)	ePM1 ≥ 50 % (F7) ISO Coarse > 30 % (G2)
IP rating		IP 21	IP 21
Dimensions			
Height	mm	285	285
Width	mm	360	360
Depth	mm	590	780
Maximum altitude for installation	m	2000	2000
Min. outlet aperture	mm	∅ 200, square 185x185	∅ 200, square 185x185
Weights			
Weight	kg	5.2	5.2
Values			
Air flow rate	m ³ /h	20/30/40/70	20/30/40/70
Air flow rate for differential mode	m ³ /h	10/15/20/35	10/15/20/35
Heat recovery level up to	%	92	92
Wall thickness	mm	100 - 300	300 - 550

		VLR 70 VUS Trend EN	VLR 70 VUL Trend EN
		239563	239567
Air flow rate	m ³ /h	20/30/40/70	20/30/40/70
Wall thickness	mm	100 - 300	300 - 550
Height	mm	180	180
Width	mm	160	160
Depth	mm	315	625

Guarantee

The guarantee conditions of our German companies do not apply to appliances acquired outside of Germany. In countries where our subsidiaries sell our products a guarantee can only be issued by those subsidiaries. Such guarantee is only granted if the subsidiary has issued its own terms of guarantee. No other guarantee will be granted.

We shall not provide any guarantee for appliances acquired in countries where we have no subsidiary to sell our products. This will not affect warranties issued by any importers.

Environment and recycling

We would ask you to help protect the environment. After use, dispose of the various materials in accordance with national regulations.

NOTES

NOTES

Deutschland

STIEBEL ELTRON GmbH & Co. KG
Dr.-Stiebel-Straße 33 | 37603 Holzminden
Tel. 05531 702-0 | Fax 05531 702-480
info@stiebel-eltron.de
www.stiebel-eltron.de

Verkauf

Tel. 05531 702-110 | Fax 05531 702-95108 | info-center@stiebel-eltron.de

Kundendienst

Tel. 05531 702-111 | Fax 05531 702-95890 | kundendienst@stiebel-eltron.de

Ersatzteilverkauf

Tel. 05531 702-120 | Fax 05531 702-95335 | ersatzteile@stiebel-eltron.de

Australia

STIEBEL ELTRON Australia Pty. Ltd.
6 Prohasky Street | Port Melbourne VIC 3207
Tel. 03 9645-1833 | Fax 03 9645-4366
info@stiebel.com.au
www.stiebel.com.au

Austria

STIEBEL ELTRON Ges.m.b.H.
Gewerbegebiet Neubau-Nord
Margaritenstraße 4 A | 4063 Hörsching
Tel. 07221 74600-0 | Fax 07221 74600-42
info@stiebel-eltron.at
www.stiebel-eltron.at

Belgium

STIEBEL ELTRON bvba/sprl
't Hofveld 6 - D1 | 1702 Groot-Bijgaarden
Tel. 02 42322-22 | Fax 02 42322-12
info@stiebel-eltron.be
www.stiebel-eltron.be

China

STIEBEL ELTRON (Guangzhou) Electric
Appliance Co., Ltd.
Rm 102, F1, Yingbin-Yihao Mansion, No. 1
Yingbin Road
Panyu District | 511431 Guangzhou
Tel. 020 39162209 | Fax 020 39162203
info@stiebeleltron.cn
www.stiebeleltron.cn

Czech Republic

STIEBEL ELTRON spol. s r.o.
K Hájům 946 | 155 00 Praha 5 - Stodůlky
Tel. 251116-111 | Fax 235512-122
info@stiebel-eltron.cz
www.stiebel-eltron.cz

Finland

STIEBEL ELTRON OY
Kapinakuja 1 | 04600 Mäntsälä
Tel. 020 720-9988
info@stiebel-eltron.fi
www.stiebel-eltron.fi

France

STIEBEL ELTRON SAS
7-9, rue des Selliers
B.P 85107 | 57073 Metz-Cédex 3
Tel. 0387 7438-88 | Fax 0387 7468-26
info@stiebel-eltron.fr
www.stiebel-eltron.fr

Hungary

STIEBEL ELTRON Kft.
Gyár u. 2 | 2040 Budaörs
Tel. 01 250-6055 | Fax 01 368-8097
info@stiebel-eltron.hu
www.stiebel-eltron.hu

Japan

NIHON STIEBEL Co. Ltd.
Kowa Kawasaki Nishiguchi Building 8F
66-2 Horikawa-Cho
Saiwai-Ku | 212-0013 Kawasaki
Tel. 044 540-3200 | Fax 044 540-3210
info@nihonstiebel.co.jp
www.nihonstiebel.co.jp

Netherlands

STIEBEL ELTRON Nederland B.V.
Daviottenweg 36 | 5222 BH 's-Hertogenbosch
Tel. 073 623-0000 | Fax 073 623-1141
info@stiebel-eltron.nl
www.stiebel-eltron.nl

Poland

STIEBEL ELTRON Polska Sp. z O.O.
ul. Działkowa 2 | 02-234 Warszawa
Tel. 022 60920-30 | Fax 022 60920-29
biuro@stiebel-eltron.pl
www.stiebel-eltron.pl

Russia

STIEBEL ELTRON LLC RUSSIA
Urzhumskaya street 4,
building 2 | 129343 Moscow
Tel. 0495 7753889 | Fax 0495 7753887
info@stiebel-eltron.ru
www.stiebel-eltron.ru

Slovakia

TATRAMAT - ohrievače vody s.r.o.
Hlavná 1 | 058 01 Poprad
Tel. 052 7127-125 | Fax 052 7127-148
info@stiebel-eltron.sk
www.stiebel-eltron.sk

Switzerland

STIEBEL ELTRON AG
Industrie West
Gass 8 | 5242 Lupfig
Tel. 056 4640-500 | Fax 056 4640-501
info@stiebel-eltron.ch
www.stiebel-eltron.ch

Thailand

STIEBEL ELTRON Asia Ltd.
469 Moo 2 Tambol Klong-Jik
Amphur Bangpa-In | 13160 Ayutthaya
Tel. 035 220088 | Fax 035 221188
info@stiebeleltronasia.com
www.stiebeleltronasia.com

United Kingdom and Ireland

STIEBEL ELTRON UK Ltd.
Unit 12 Stadium Court
Stadium Road | CH62 3RP Bromborough
Tel. 0151 346-2300 | Fax 0151 334-2913
info@stiebel-eltron.co.uk
www.stiebel-eltron.co.uk

United States of America

STIEBEL ELTRON, Inc.
17 West Street | 01088 West Hatfield MA
Tel. 0413 247-3380 | Fax 0413 247-3369
info@stiebel-eltron-usa.com
www.stiebel-eltron-usa.com



Irrtum und technische Änderungen vorbehalten! | Subject to errors and technical changes! | Sous réserve d'erreurs et de modifications techniques! | Onder voorbehoud van vergissingen en technische wijzigingen! | Salvo error o modificación técnica! | Excepto erro ou alteração técnica | Zastrzeżone zmiany techniczne i ewentualne błędy | Omyly a technické změny jsou vyhrazeny! | A muszaki változtatások és tévedések jogát fenntartjuk! | Отсутствие ошибок не гарантируется. Возможны технические изменения. | Chyby a technické zmeny sú vyhradené!

Stand 9147

STIEBEL ELTRON

A 331411-40913-9368
B 331766-40913-9368